



684 3-DK

INCLINED SCREEN



STRONG **HERITAGE**, STRONG **FUTURE**



684 3-DK

INCLINED SCREEN



The Finlay® 684 3-Deck inclined screen is a compact easily transportable machine that offers operators rapid set up and tear down times.

The screenbox features three large 4.3m x 1.7m (14' x 5' 7") inclined screens giving a large screening area of 236ft² to provide efficient screening and high capacity. The screenbox features quick wedge tensioning, access holes and bottom deck hydraulic tensioning system to reduce time required for mesh changes.

All four discharge conveyors are adjustable and hydraulically fold for transport. The fourth product 'oversize plus' conveyor has variable tilt and side slew to accurately discharge material for recirculation and stockpiling.

The model is available with hybrid technology consisting of on-board electrical motors permitting the flexibility to run the plant from an outside power supply or standard on-board engine.

FEATURES:

- Machine can operate on either On-Board Engine or External Power Supply.
- Triple deck 4.3m x 1.7m (14' x 5' 7") screen with full catwalk access.
- The fourth (oversize plus) conveyor provides variable tilt and slide slew capability to accurately discharge materials for recirculation to crushers or for stockpiling.
- Maximum utilisation of three 4.3m x 1.7m (14' x 5' 7") decks provides ultra-efficient screening capabilities even at small aggregate sizes.
- A combination of quick wedge tensioning, convenient access holes and hydraulic tensioning on the bottom deck ensure mesh set up and change out times are kept to an absolute minimum.
- Optional Vibrating grid available to separate bigger size material for ROM screening.

TRANSPORT DIMENSIONS

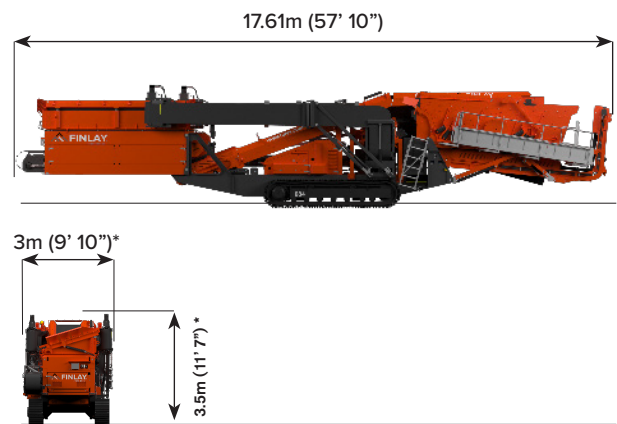

WORKING DIMENSION

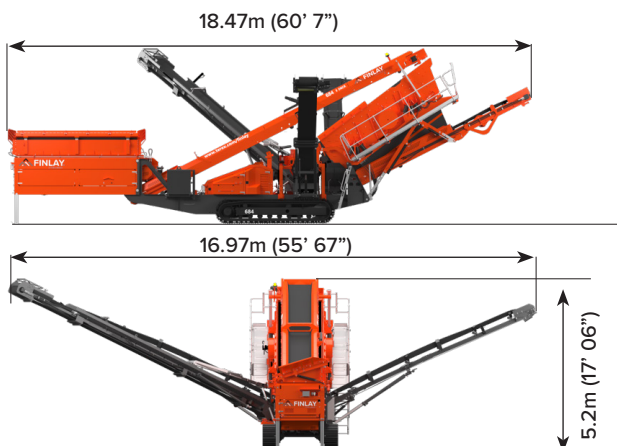

MACHINE WEIGHT:

* 33,500kg (73,800lbs)
* Standard Machine Configuration

1. HOPPER/FEEDER

Hopper Capacity: 8m³ (10.5yd³)

Feed height: 3.51m (11' 6")

Feed in width: 4.77m (15' 8") (grid wing plates)

Beltfeeder belt width: 1.05m (42")

2. OVERSIZE PLUS CONVEYOR

Belt width: 500mm (20")

Working Angle: 20° - 23°

Discharge Height: variable 4.47m (max)

Operating angle variable between 40° and 60°

Stockpile capacity: 123m³ (162³yd)

3. MAIN CONVEYOR

Belt width: 1m (40")

Steel skirted full length of conveyor

2 number Anti-rollback Plates

Hydraulic Slide adjust

4. MIDDLE GRADE CONVEYOR

Belt width: 650mm (26")

Working Angle: 24°

Hydraulic Folding

Discharge Height: 4.76m (15' 7")

Stockpile capacity: 147m³ (192yd³)

5. UNDERCARRIAGE

Shoe Width: 400mm (16")

Speed: 0.8 km/h

Gradeability: 25.5°

Raking Angle: 8°

6. SCREENBOX

Both decks: 4.3m x 1.7m (14' x 5' 7")

Screen Angle: 18° - 37°, hydraulic adjust

Galvanised access catwalk at both sides and top end of screen

Total screening area: 21.9m² (235ft²)

7. POWER UNIT

Tier 3 / Stage IIIA: Caterpillar 4.4

Engine Power: 83kW (111hp)

Engine Speed: 1800 rpm

Dual Power - 2X37kW Motors

8. FINES CONVEYOR

Belt width: 1.2m (48")

Working Angle: Variable 25° (Max)

Standard Discharge Height: 4.15m (13' 7")

Stockpile capacity: 106.3m³ (139yd³) @ 25°





The material in this document is for information only and is subject to change without notice.

Finlay® assumes no liability resulting from errors or omissions in this document, or from the use of the information contained herein.

Due to continual product development we reserve the right to change specifications without notice. Product performance figures given in this brochure are for guidance purposes only, this information does not constitute an expressed or implied warranty or guarantee, but shows test examples. These results will vary depending on application. Photographs are for illustrative purposes only; some or all of the machines in the illustrations may be fitted with optional extras. Please check with your Dealer for details on optional extras.

Published and Printed in 2022

Topor Basu

E: sales@terexfinlay.com

T: +91 4344 352 200

M: +91 88702 91212200

www.terex.com/finlay

