

**TECHNICAL
SPECIFICATION**



A TEREX BRAND

TC80 ORGANICS TRACKED CONVEYOR



**RECORD, DISPLAY
AND ANALYSE DATA**



WWW.TEREX.COM/CBI

TC80 ORGANICS

ELECTRIC OPTION AVAILABLE 

DIMENSIONS

Transport	Length	12.4 M (40'-8.6")
	Width	2.565 M (8'-5")
	Height	3.96 M (13'-0")
Working @24°	Length (Overall)	22.6 M (74'-2")
	Width	3.83 M (12'-7")
	Height (Top of Drum)	3.96 M (13'-0")
Total Weight (STD) (kg)	13,000	
Maximum Tonnage	600 TPH (DEPENDENT ON MATERIAL AND BULK DENSITY)	
Maximum Feed Size	150 MM (DEPENDENT ON MATERIAL AND BULK DENSITY)	

FEEDBOOT

Standard Capacity	8.65 M ³ (11.31 YD ³)
Extended Capacity	8.65 M ³ (11.31 YD ³)
Standard Feed In Width	3.7 M (12'-2")
Extended Feed In Width	3.7 M (12'-2")
Standard Minimum Feed In Height @24°	2.55 M (8'-4")
Extended Minimum Feed In Height @24°	2.55 M (8'-4")
Auger Speed	110RPM
Auger Control	Flow control and directional

CONVEYORS

Width	1200MM (48")
Belt Centres	22.69 M (74'-5")
Belt Type (Plain/Chevron)	CHEVRON
Belt Spec	EP400/3PLY 3+1.5 OR EQUIVALENT
Drive Drum Diameter	376 MM (14.8")
Tail Drum Diameter	275 MM (11")
Max Belt Speed of Conveyor	2.72 M/SEC
Motor Size & type	TWIN OMV 400CC
Operating Angle	0-24°
Variable Speed (Y/N)	YES

Discharge Height @ 10°	5.74 M (18'-10")
Stockpile Capacity @ 10° & 37° Angle of Repose	348.8 M ³ (456 YD ³)
Discharge Height @ 12°	6.37 M (20'-11")
Stockpile Capacity @ 12° & 37° Angle of Repose	476.7 M ³ (623.5 YD ³)
Discharge Height @ 14°	7 M (23'-0")
Stockpile Capacity @ 14° & 37° Angle of Repose	632.5 M ³ (827.3 YD ³)
Discharge Height @ 16°	7.6 M (24'-11")
Stockpile Capacity @ 16° & 37° Angle of Repose	810 M ³ (1059 YD ³)
Discharge Height @ 18°	8.22 M (27'-0")
Stockpile Capacity @ 18° & 37° Angle of Repose	1024 M ³ (1340 YD ³)
Discharge Height @ 20°	8.82 M (28'-11")
Stockpile Capacity @ 20° & 37° Angle of Repose	1265 M ³ (1655 YD ³)
Discharge Height @ 22°	9.42 M (30'-11")
Stockpile Capacity @ 22° & 37° Angle of Repose	1541.5 M ³ (2016 YD ³)
Discharge Height @ 24°	10 M (32'-10")
Stockpile Capacity @ 24° & 37° Angle of Repose	1844 M ³ (2412 YD ³)



TC80 ORGANICS

ELECTRIC OPTION AVAILABLE 

MAIN CONVEYOR

- Heavy duty head and tail drums.
- Varied angle roller sets.
- Impact bars on tail section.
- Hydraulic folding head section.
- Full Side Skirting.

POWER UNIT & HYDRAULICS

T3 Engine

Engine Type and Power Rating	CAT 4.4 LRC - 74KW
RPM	2400 RPM MAX
Crankshaft Pump	51cc - 20cc Tandem
PTO Pump	None

T4F Engine

Engine Type and Power Rating	CAT 2.8 TIER 4 STAGE V - 55KW
RPM	2400 RPM MAX
Crankshaft Pump	51cc - 20cc Tandem
PTO Pump	None

Stage V Engine

Engine Type and Power Rating	CAT 2.8 TIER 4 STAGE V - 55KW
RPM	2400 RPM MAX
Crankshaft Pump	51cc - 20cc Tandem
PTO Pump	None

Tank Capacities

Diesel Tank Capacity	232 LT (61 US GALLON)
Hydraulic Tank Capacity	425 LT (112 US GALLON)



OPTIONS

- Dual Power (Electric/Hydraulic/Diesel/Hydraulic)
- Heavy Duty 4 Ply Belt
- Chevron Belt C25
- Feedboot liners
- Cordless Remote Control Tracks

- Under Guarding Covers
- Basket guards
- Manual Jacking Leg System
- Anti Roll Back Flaps

TRACKS

Shoe Width (mm)	400
Sprocket Centre (mm)	2909
Speed (KM/H) (Low)	1.5
Speed (KM/H) (High) / Or Single Speed	2.7

TC80 ORGANICS

ELECTRIC OPTION AVAILABLE 

TRANSPORT

Transport Container

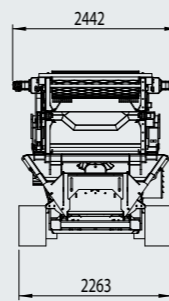
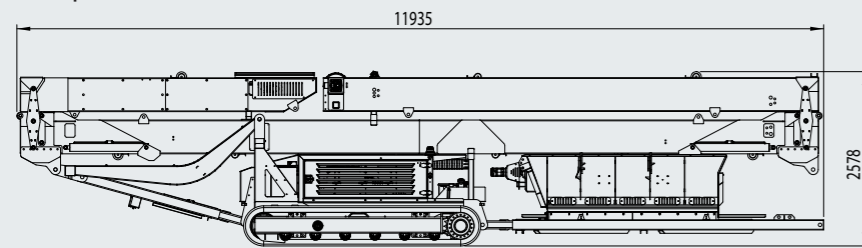

Transport Road

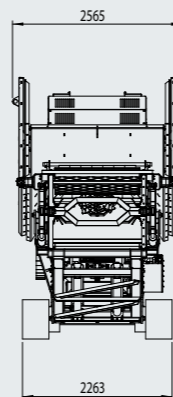
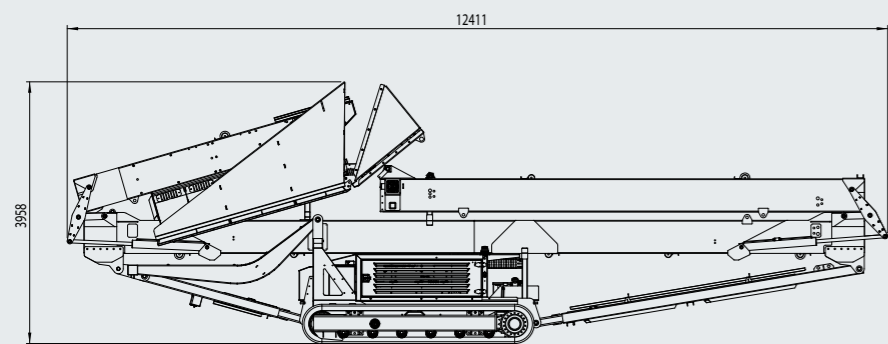

WORKING

Working 18°

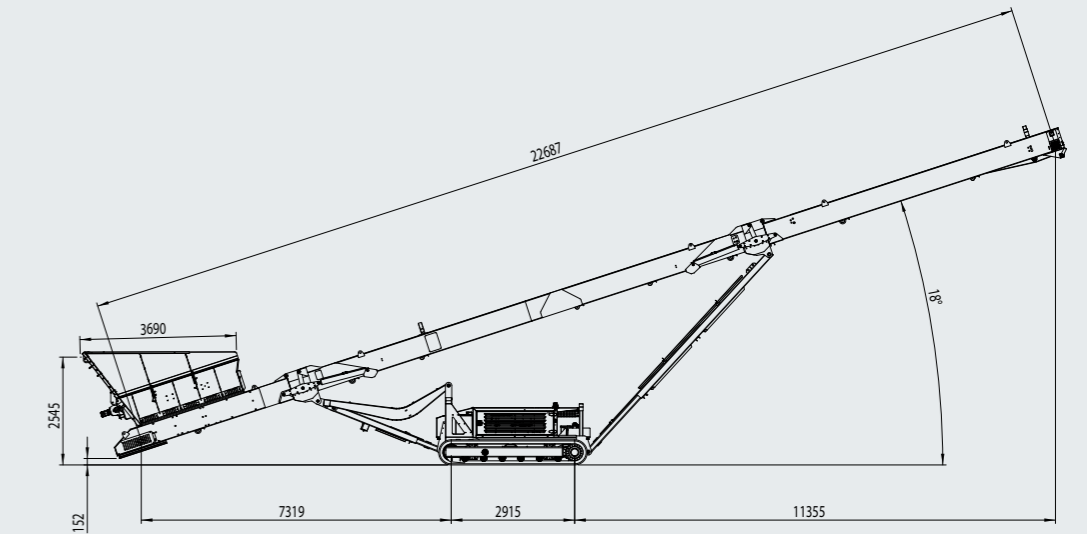
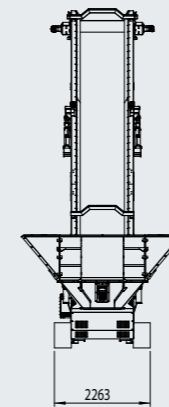
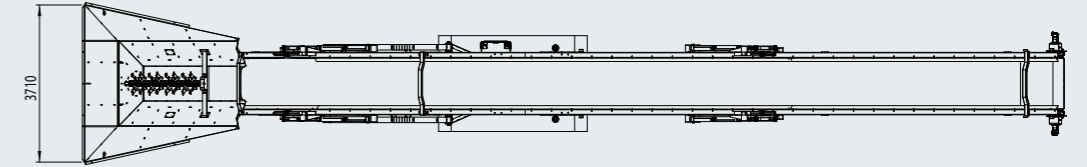

Working 24°

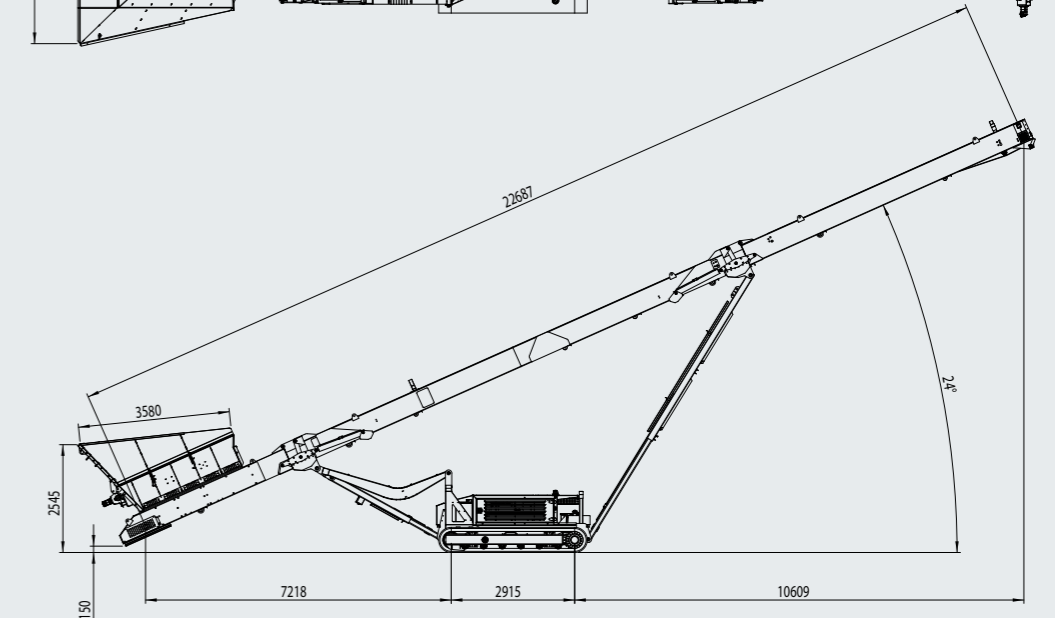
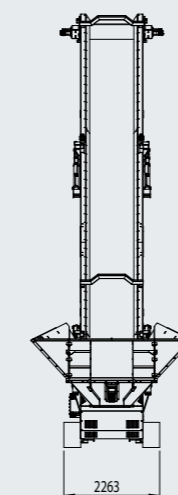
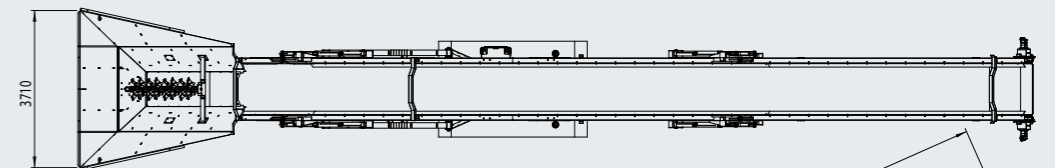



A TEREX BRAND

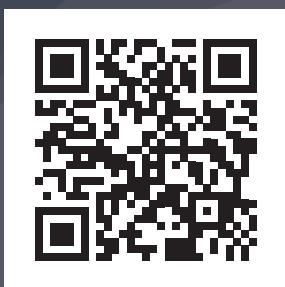

The material in this document is for information only and is subject to change without notice.

CBI assumes no liability resulting from errors or omissions in this document, or from the use of the information contained herein. Due to continual product development we reserve the right to change specifications without notice. Product performance figures given in this brochure are for guidance purposes only, this information does not constitute an expressed or implied warranty or guarantee. Results will vary depending on conveyor settings, feed source and types of material being processed.

Images are for illustrative purposes only, some or all of the machines in the illustrations may be fitted with optional extras. Please check with your Dealer for details on optional extras.

CBI is a registered trademark of Terex GB Limited in the United States of America and many other countries.
Copyright 2025 Terex. Published and Printed in 2025.